



A CRH COMPANY

# ULTIMA Connect Assembly Method

STAKKAbox™

ULTIMA Connect

The STAKKAbox™ ULTIMA Connect chamber system features a twinwall sectional design that is made up of GRP corner pieces ('hockey sticks') and sidewall lengths. These parts are connected using a jointing peg to form a variety of clear opening sizes. Sidewall sections used in conjunction with corner sections allows chamber sizes specified by the contractor to be created. Chamber accessories are also available as shown below.

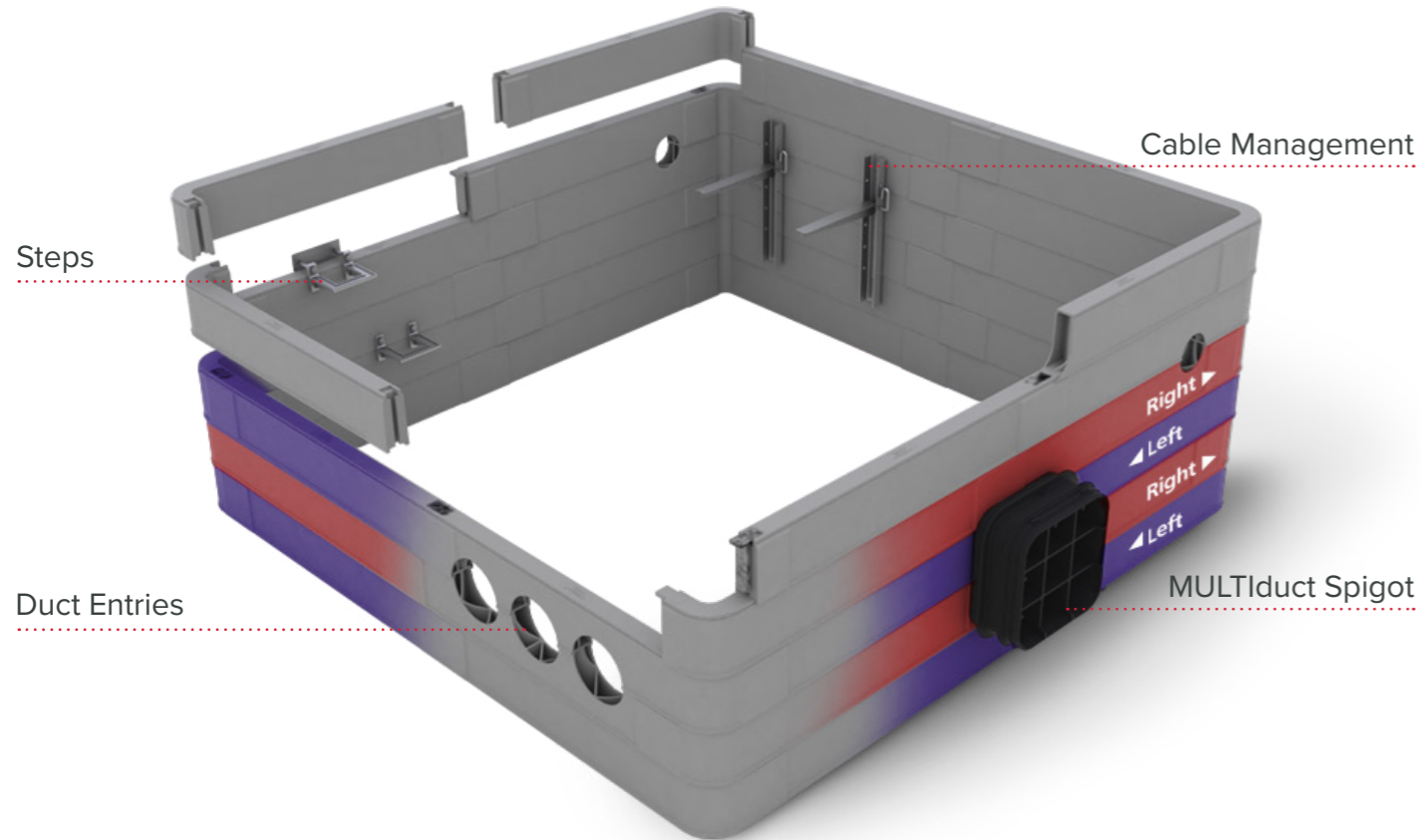

## Components (mm)

### Corner Sections

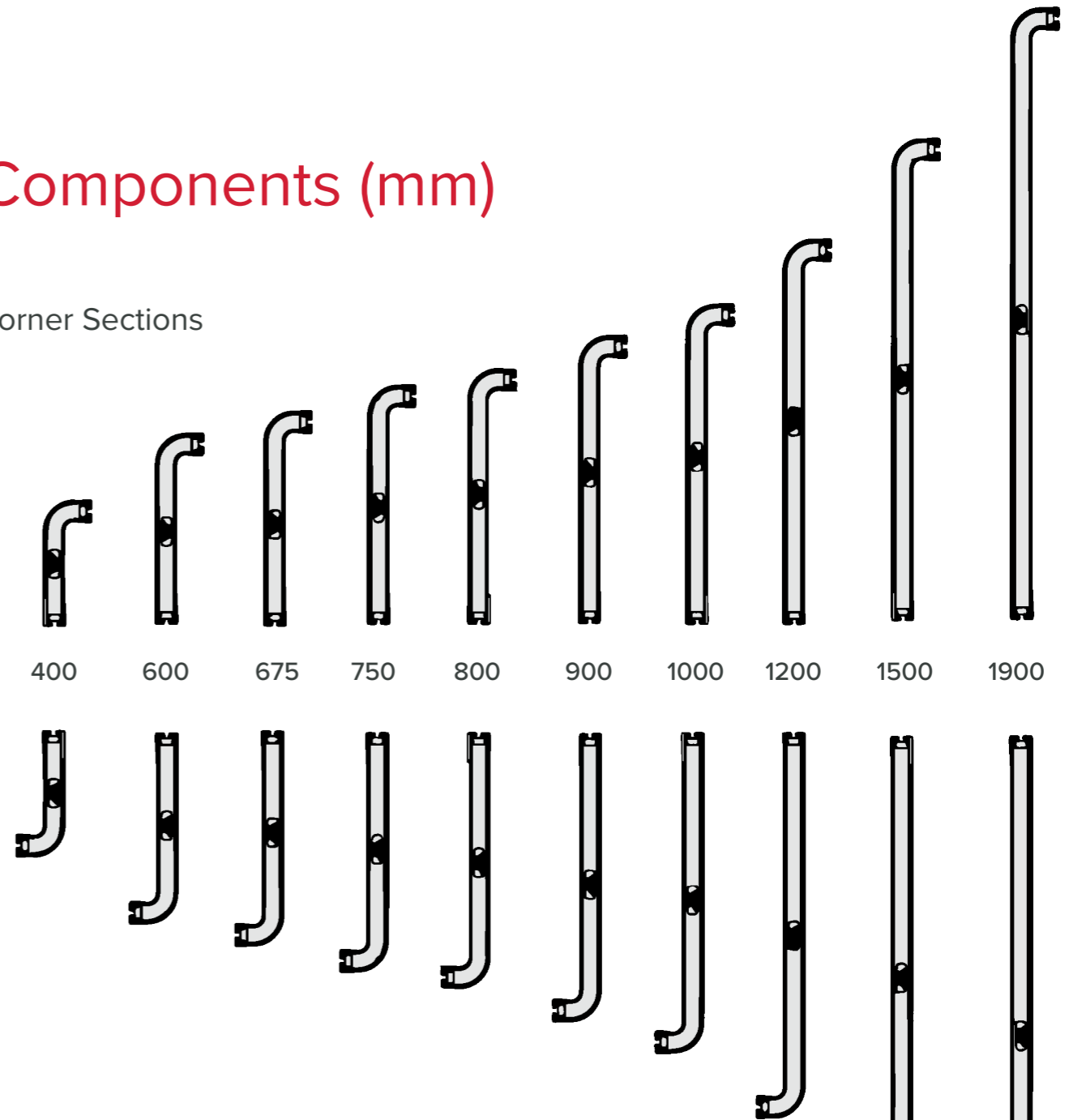

### Sidewalls

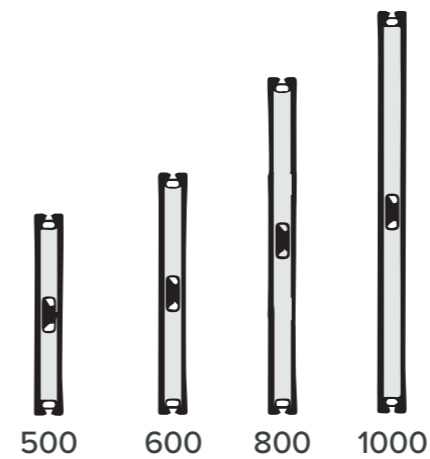

### Jointing Pegs

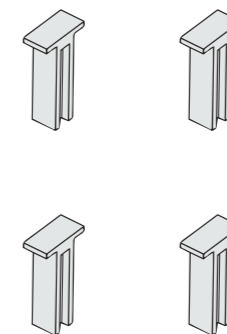

# Assembly Method

## Using Corner Sections

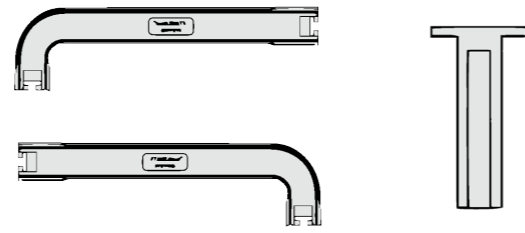

- 1** a) Arrange corner pieces to match the chamber clear opening dimensions. Ensure that the lip is on the outside of the chamber. The corner pieces should be all 'left' or all 'right' on each section and will alternate between the two as the chamber increases in depth. b) Connect the sections using joining pegs, ensuring that the top of the peg is level with the top of the section. All pegs should be partially inserted before tapping.

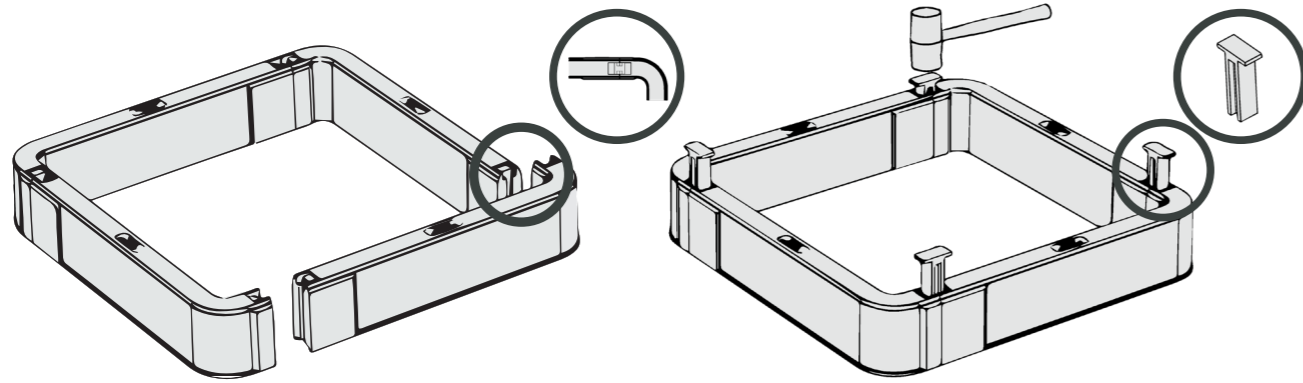

- 2** a) Using the alternative corner piece arrangement, lay out the second ring section of connect pieces to ensure you have the correct components. b) Arrange the component parts sequentially as shown below. This will provide a 'brick worked' chamber ensuring any joints are not in a vertical line.

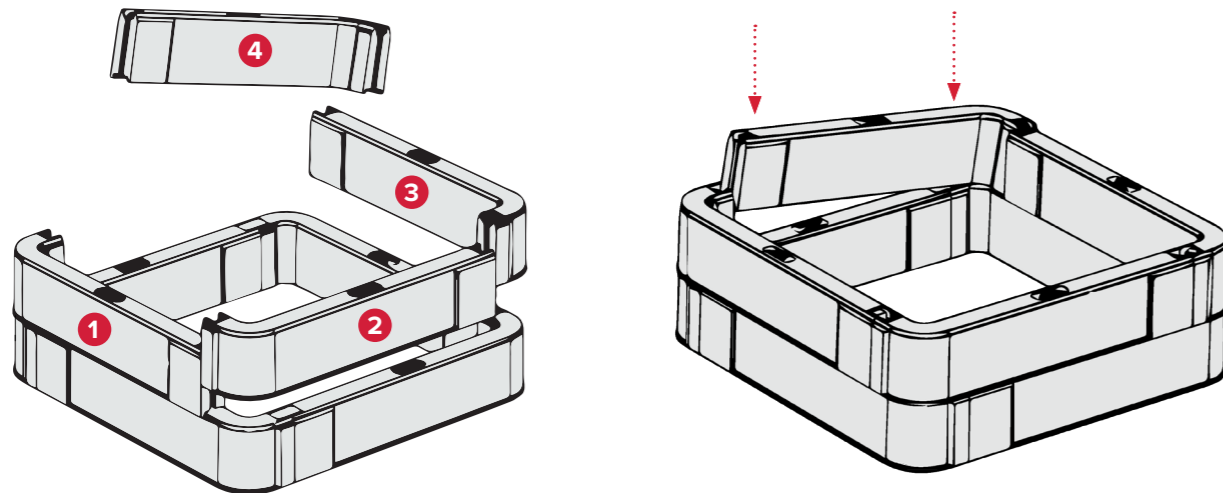

- 3** Connect the sections using joining pegs, ensuring that the top of the peg is level with the top of the section. Repeat steps 1 to 3 until the chamber reaches the specified depth.

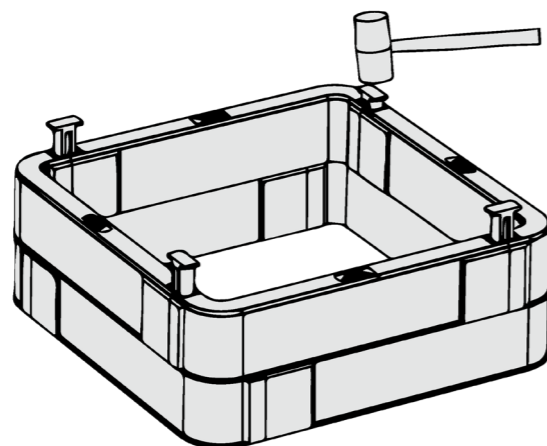

# Assembly Method

## Using Corner Sections and Straight Lengths

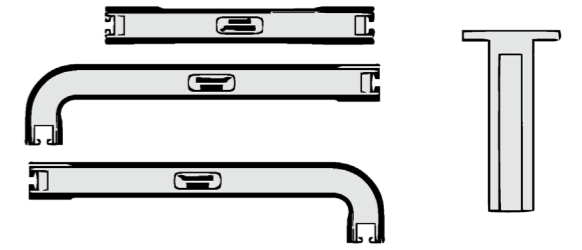

- 1** a) Arrange corner pieces and side walls to match the chamber clear opening dimensions. Ensure that the lip is on the outside of the chamber. The corner pieces should be all 'left' or all 'right' on each section and will alternate between the two as the chamber increases in depth. b) Connect the sections using joining pegs, ensuring that the top of the peg is level with the top of the section. All pegs should be partially inserted before tapping.

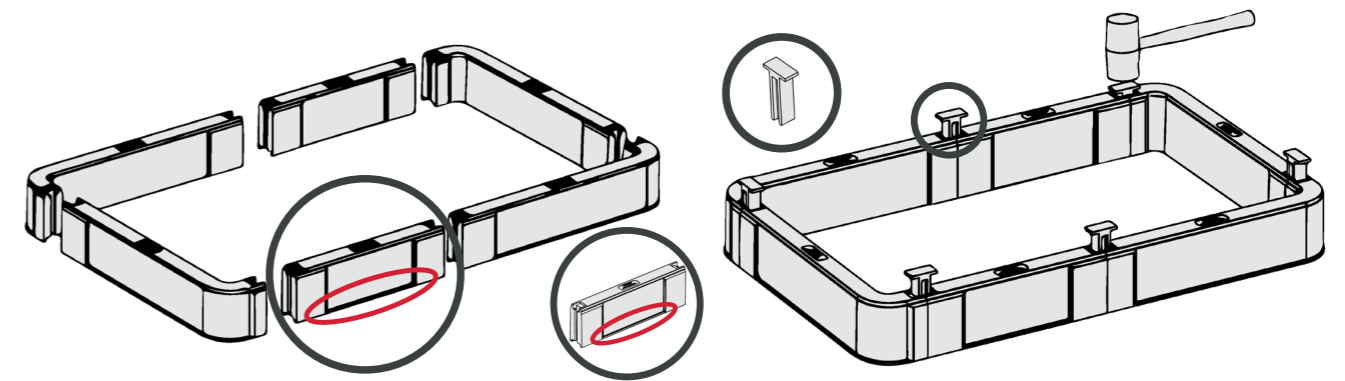

- 2** a) Using the alternative corner piece arrangement, lay out the second ring section of connect pieces to ensure you have the correct components. b) Arrange the component parts sequentially as shown below. This will provide a 'brick worked' chamber ensuring any joints are not in a vertical line.

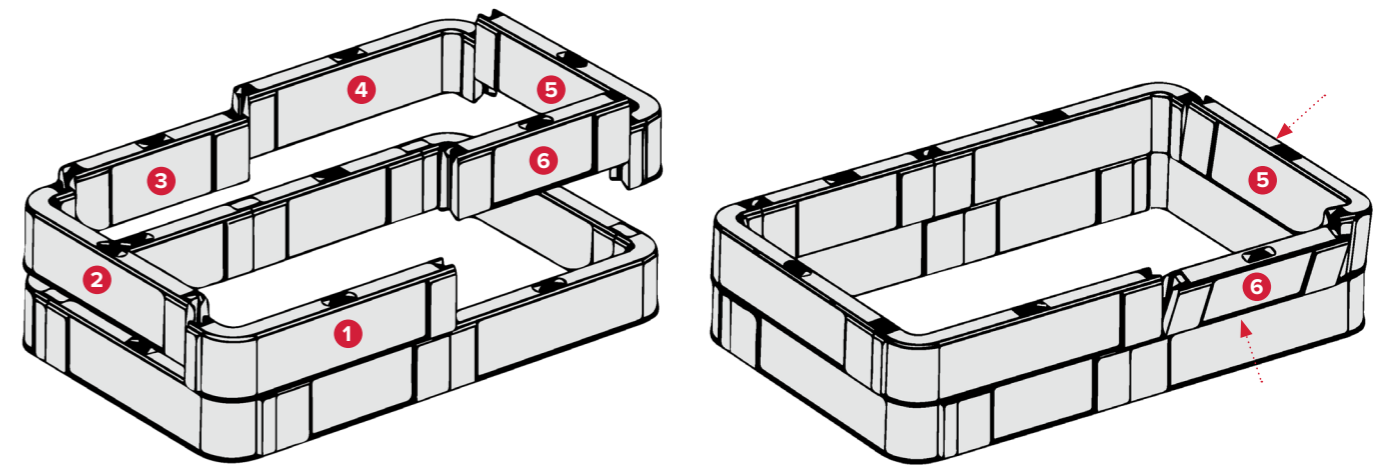

- 3** Connect the sections using the joining peg, ensuring that the top of the peg is level with the top of the section. Repeat steps 1 to 3 until the chamber reaches the specified depth.

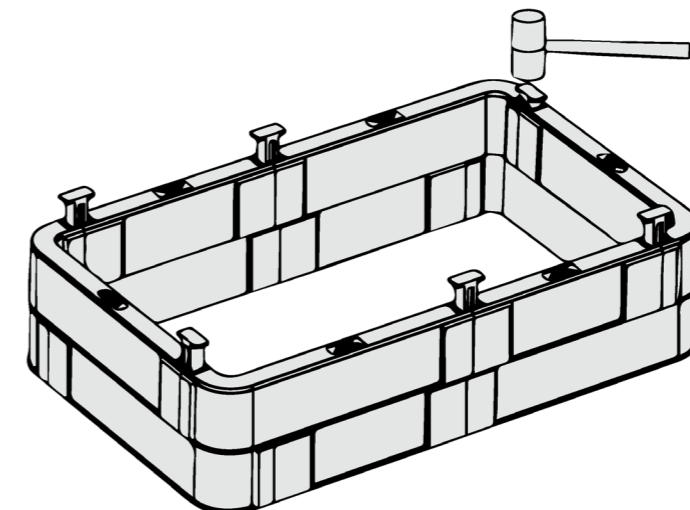

## Contact us:

Head Office:  
4 Silverwood Industrial Estate,  
Lurgan, Co. Armagh,  
BT66 6LN,  
Northern Ireland

Telephone: +44 (0)28 38 313 100  
Email: [info@cubis-systems.com](mailto:info@cubis-systems.com)

[www.cubis-systems.com](http://www.cubis-systems.com)



## Driven by Innovation

Cubis is Europe's leading manufacturer of network access chamber and ducting systems, used in the construction of infrastructure networks for rail, telecoms, water, construction and power markets.

Cubis has developed an innovative approach in an old-fashioned industry. This has been achieved by developing quality products which replace traditional construction materials, like bricks and concrete, with lightweight plastics incorporating intelligent design features. These can then be installed faster and ultimately save our customers both time and money.

Cubis manufactures preformed network access chamber systems STAKKAbox™, AX-S™ access covers, cable protection, MULTIduct™ and PROtrough cable trough at its manufacturing sites throughout the UK and Ireland these products are exported to more than 25 countries throughout the World.

At Cubis we pride ourselves on delivering technical customer support, new innovation, product quality and the highest levels of customer satisfaction.