

Product name	Counterweight device for AGS-clamp Counterweight device for
Product code	0626546
Product type	4370.57/10
GTIN	7332811074448
ETIM-Class	

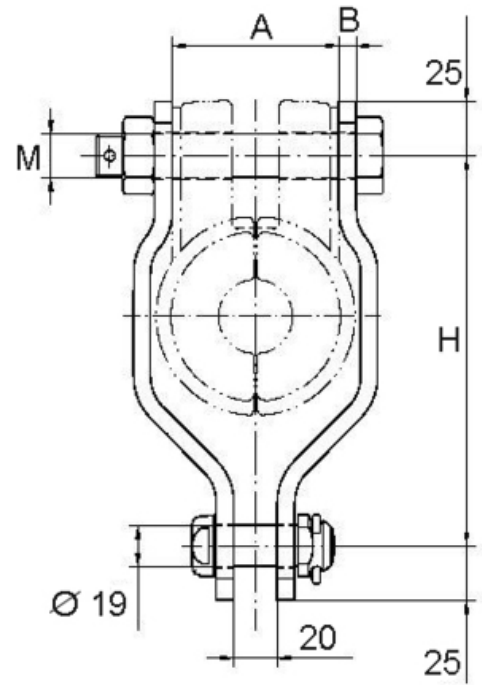

Measurements

Length	230 mm
Height	40 mm
Width	122 mm
Weight	1 900 g

Technical Specifications - String Hardware

Bolt Diameter	19 mm
Conductor Diameter	23,06-25,54 mm
Conductor Cross Section	319-329 mm ²
Material	varmgalvaniserat stål
Dimension A	77 mm
Dimension h	195 mm
Dimension M	m20 mm